

User Manual

General Purpose Data Logger ALL-xx

Firmware revision 2.0b and higher.

Description:

This general purpose Data Logger will capture all data received.

Capture bit-rate can be set to 2400,4800,9600,19200bps.

This product is useful for storing general NMEA data from a GPS receiver, as well as other data logging requirements.

This product is an economical and lightweight substitute for a laptop computer in field work, especially if there is a chance of damage or loss to the field experiment.

Features:

Low power operation. Current requirement typically 1.2mA.

Up to 10 days operation from a 9V alkaline battery

Can be operated from external power source, 10V to 30V dc.

Up to 68.8Mb (8.6MB) non-volatile flash memory.

Stored data is retained in non-volatile memory the event of power failure.

Capture bit-rate can be set to 2400,4800,9600,19200bps.

Download via standard serial port at 57600 or 115200 baud.

Easy to Field-configure using DIP switches. No PC required to configure.

Theory Of Operation:

The Datalogger has two modes, 'save' and 'command'.

These modes are selected by an internal input on pin 1 of the DB9 connector.

When pin 1 is open or 'high', the Logger is in 'Save' mode and will store text data.

When pin 1 is pulled 'low' to ground, the logger is in 'Command' mode and will accept commands.

Download Software:

No special download utility is required. All that is needed is a general-purpose communications package such as Windows Hyperterm.

Event Button: (on outside of case, if fitted)

Not fitted to this model.

Pushbuttons: (inside battery compartment)

Press BOTH buttons at once to reset the logger and clear all memory.
Press button S2 alone, to cancel a download.

DIP Switches: (inside battery compartment)

Use these switches to enable various options.

Helpful Tip: You can use a corner of the battery compartment lid to operate the DIP switches.

DIP switch 1:

OFF: Download/command bit rate 57600 bps
ON: Download/command bit rate 115200 bps

DIP Switch 2:

Reserved. Leave OFF.

DIP Switches 3,4:

Capture bit rate.

Capture Bit-rate	DIP 3	DIP 4
2400	OFF	OFF
4800	OFF	ON
9600	ON	OFF
19200	ON	ON

GPS/Data Source set-up:

This set-up would apply to any ASCII data source, not only a GPS...

Ensure that your data output is set to **NMEA, or other text output.**

Insert the battery and connect the logger to your GPS.

The LED will flash if NMEA data is being received from the GPS.

Battery Installation:

Stored data will not be lost if battery is disconnected. This product uses non-volatile Flash memory.

Use a 9 volt alkaline battery, type MN1604, PC1604, 522, 6LR61 or equivalent.

Open the battery compartment by gently pressing and sliding the battery cover towards the edge of the case.

Attach the battery clip to the battery.

Place the battery in the battery compartment. Ensure that the battery clip wires are clear of the DIP switches and push buttons.

External Power:

External power between 10V and 30V dc can be applied to pin 9 of the data connector.

The 9V battery may be safely left in place when external power is applied.

The 9V battery will not be discharged when external power is applied.

Example Wiring Diagram:

In this example, the 10k resistor, R1, will allow the PC to over-ride the GPS receiver, enabling download without disconnecting the GPS.

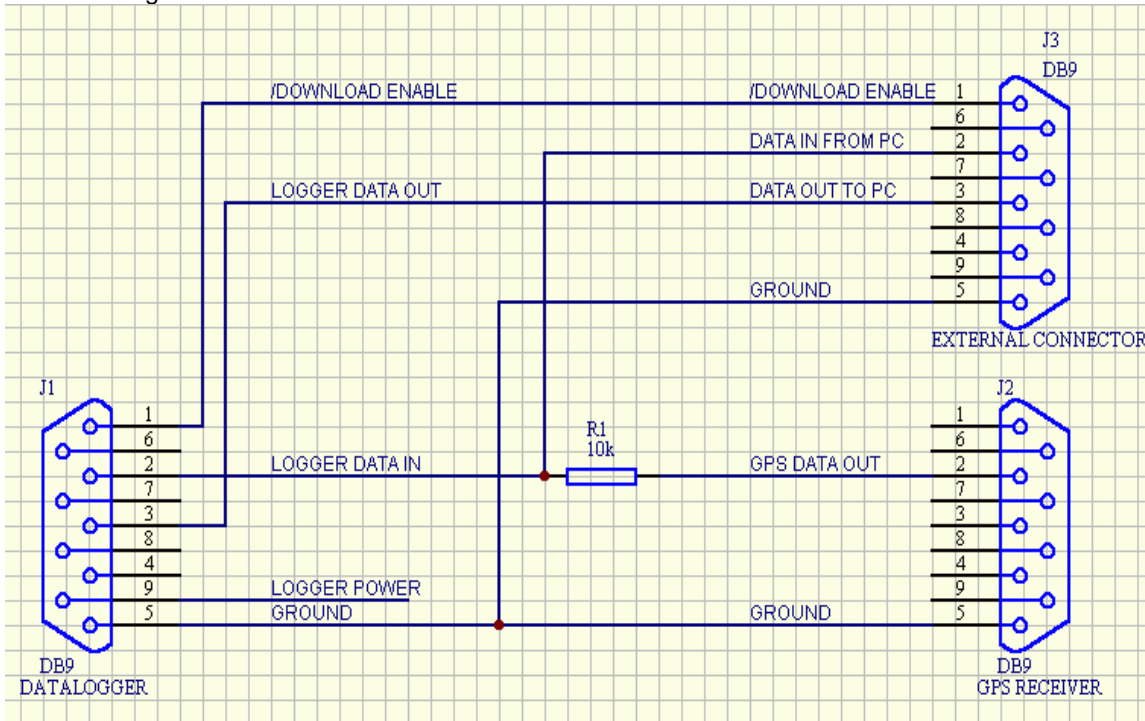

LED Indicator:

The LED indicator flashes when data is received. The number/length of flashes gives you information about the Data Logger status.

The LED will flash every time a 'CR' (Carriage Return) character is received.

ONE flash: 'CR' character has been received. System OK.

ONE LONG Flash: 'CR' character received, System fault. Eg Low battery, memory full.

ON constant: Download in progress.

ON constant on power-up: System fault.

Note: The LED will only flash if data is received. This is because the logger goes into power-save mode if there is no data, in order to improve battery life and protect stored data.

DB9 pin-out:

Pin 5 Ground (Power and Data)

Pin 9 External Power 10V to 30V dc.

Pin 2 Receive Data (From GPS)

Pin 3 Transmit Data (To PC)

Pin 1 Download Mode Control. Connect to Ground to enter Download mode.

Logger to PC Cable:

The logger to PC cable is used to download data from the logger to your PC, and is basically a serial lap-link (null-modem) cable. This cable must connect pin 1 of the Data Logger DB9 connector, to pin 5 (ground) to enable download mode. This can be hardwired into the cable at the Data Logger connector, or a switch can be placed at the PC end of the data cable.

A download cable is provided. One end is marked 'PC', and connects to your computer. The other end is marked 'DL', and connects to the Datalogger. The connector marked 'DL' has pins 1 and 5 connected internally, to enable download mode.

Garmin 12XL Power/data cable: (option)

This cable has three connectors: Garmin GPS plug, DB9 Logger connector and car lighter socket plug. Voltage applied to the lighter plug will be supplied to both the GPS and the datalogger.

WARNING: Some Garmin GPS units are not rated for more than 8V power. You must ensure that your GPS can handle the supplied DC voltage before using this cable.

Garmin eTrex/eMap Power/data cable: (option)

This cable has three connectors: eTrex GPS plug, DB9 Logger connector and car lighter socket adapter. 3 volts will be supplied to the eTrex, voltage applied to the lighter plug will be supplied to the datalogger.

Map Datums:

The NMEA position data sent by **Garmin** GPS units follows the map datum selected in the navigation setup menu. It is important that you set your GPS map datum to the same datum as you will use with your mapping software. **WGS84 is recommended.**

Specifications:

Storage Modes/capacities:

Storage Capacity:

ALL-XM8: Approx. 8.6 million characters.

When memory is FULL, new data will not be stored: existing data will be protected.

Indicator:

High efficiency LED flashes when data is received.

Electrical:

External Voltage: 10-30V DC.

Supply Current: Active 1.2mA Typ

Standby 50uA Typ

Main Battery: 9V Alkaline type MN1604, PC1604, 522, 6LR61 or equivalent.

Memory Backup: Nonvolatile Memory, 10-years with no power.

Interface:

9 pin male D connector for Data/Power.

Pin 2: Receive Data (From GPS)

Pin 3: Transmit Data (To PC)

Pin 5: Common Ground

Pin 9: External Power Input

Pin 1: Download Mode Control

RS-232-E Logic level serial data.

Compatible with typical GPS 5V data output.

Compatible with RS232 levels.

Physical:

Dimensions: 66 x 112 x 28 millimetres

Weight: 200 grams

Colour: Light Grey

Case Material: ABS

Commands:

The following command set may be used with a terminal program, or as a guide for writing your own datalogger communications software.

Note:

Commands are accepted ONLY when pin 1 of the Datalogger connector is connected to Ground.

Download:

Lowercase 'd'. The Data Logger will instantly download all stored data at the baudrate selected by DIP switch 1.

Datalogger will send 'ok' when the download is complete.

Download can be cancelled by pressing the Escape key.

Download can be cancelled by pressing pushbutton S2 (inside the battery compartment).

Info:

Lowercase 'i': The Data Logger will instantly return version and model number data.

Zero (Clear)

Uppercase 'Z' (Shift-Z). All data will be instantly cleared from memory.

Datalogger will reply with 'ok'

Example Download Sequence: Using Hyperterm.

Below is a typical download sequence using Windows Hyperterm. Use it as a general guide for your own operations.

Set-Up

- 1) Connect the Logger to PC cable. Remember to connect the plug labelled 'DL' to the Datalogger, and the plug marked 'PC' to the computer RS232 serial port.
- 2) Start Hyperterm.
- 3) Find the Properties menu and select 'Direct to Comm port'. Select the correct comm. port eg Comm 1, Comm2, etc. Also set the port speed to 57600 or 115200 depending upon the download speed you require from the Logger. Set the flow control to 'software' or 'Xon-Xoff'.
- 4) After changing Comm settings, you will need to click on the 'disconnect' and 'connect' buttons in the main menu bar to enable those settings.
- 5) Verify your connection by connecting the Logger to the appropriate port and pressing the 'i' key. (MUST be a lowercase 'i'. Check your CAPS LOCK status). You should get an Info message response from the Logger.

Download:

- 1) From the Hyperterm menu, select Transfer-Capture Text. You will be prompted for a filename. Browse for an existing target file or type in a path and filename that you wish to save data into.
- 2) Click the 'start' button to enable data capture.
- 3) With the Logger connected, send a lowercase 'd' to the logger by pressing the 'd' key on your keyboard. (MUST be a lowercase 'd'. Check your CAPS LOCK status). Download should begin and you should see the received data flashing across the screen.
- 4) When download is complete the logger will send 'ok'
- 5) Stop data capture using the 'transfer-capture text-stop' menu selections.

Warranty:

This product is warranted to be free from defects in materials and workmanship for 90 days from the date of purchase. The manufacturer will, at its sole option, repair or replace any components that fail under normal usage during this period. The Customer is, however, responsible for any transportation costs. This warranty does not cover failures due to abuse, misuse, accident, tampering or unauthorised alteration or repairs.

In no event shall the manufacturer be liable for any direct, indirect or consequential damages, whether resulting from the use, misuse, or inability to use this product, or from defects in the product.

FCC Statement:

This device complies with part 15 of the FCC rules. Operation is subject to the following two conditions: (1) This device may not cause harmful interference, and (2) this device must accept any interference received, including interference that may cause undesired operation.

Notes:

Due to ongoing product development and improvement, this user manual and specification is subject to change without notice.

“Garmin” is a registered trademark of Garmin Corporation.

“Magellan” is a registered trademark of Magellan Corporation.

Contact Information:

Web: www.gps-datalogger.com

Email: robk@tig.com.au

Fax: +61 (0)2 9759 9558

Copyright © Robert I Keskull 1999-2002